



# 12 days of fire safety

Fire safety is everyone's responsibility



Toronto  
Community  
Housing

1



Keep trees fresh by watering daily.

2

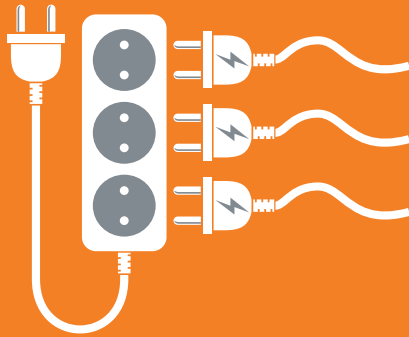

Use extension cords wisely. Do NOT overload electrical outlets.

3



Test your smoke alarms. Call 416-981-5500 if your alarm isn't working.

4

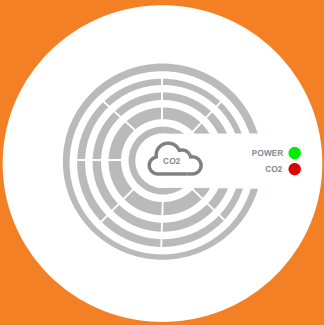

If you have a carbon monoxide alarm, make sure it's working.

5



Create a fire escape plan so everyone knows how to get out safely.

6

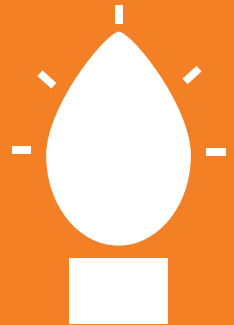

Inspect electrical decorations for fraying or damage before use.

7

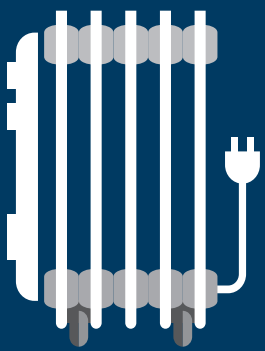

Keep space heaters at least one metre away from anything that can burn.

8



When you go out, blow out candles or use flameless candles.

9



Keep matches and lighters out of sight and reach of children.

10



Stay in the kitchen when cooking, especially if using high temperatures or oil.

11



Smoke outside. Careless smoking is one of the leading causes of fatal fires.

12



Keep an eye on anyone cooking or smoking under the influence of alcohol.

Go to [torontohousing.ca/firesafety](https://torontohousing.ca/firesafety) for more tips like these.